

点	名称	標高	備考
NO.0	119479.000	44434.001	
IP.1	119487.000	44433.002	
IP.2	119484.000	44434.003	
IP.3	119486.000	44434.004	
IP.4	119489.000	44434.005	
IP.5	119490.000	44434.006	
IP.6	119491.000	44434.007	
IP.7	119492.000	44434.008	
IP.8	119493.000	44434.009	
IP.9	119494.000	44434.010	
IP.10	119495.000	44434.011	
IP.11	119496.000	44434.012	
IP.12	119497.000	44434.013	
IP.13	119498.000	44434.014	
IP.14	119499.000	44434.015	
IP.15	119500.000	44434.016	
IP.16	119501.000	44434.017	
IP.17	119502.000	44434.018	
IP.18	119503.000	44434.019	
IP.19	119504.000	44434.020	
IP.20	119505.000	44434.021	
IP.21	119506.000	44434.022	
IP.22	119507.000	44434.023	
IP.23	119508.000	44434.024	
IP.24	119509.000	44434.025	
IP.25	119510.000	44434.026	
IP.26	119511.000	44434.027	
IP.27	119512.000	44434.028	
IP.28	119513.000	44434.029	
IP.29	119514.000	44434.030	
IP.30	119515.000	44434.031	
IP.31	119516.000	44434.032	
IP.32	119517.000	44434.033	
IP.33	119518.000	44434.034	
IP.34	119519.000	44434.035	
IP.35	119520.000	44434.036	
IP.36	119521.000	44434.037	
IP.37	119522.000	44434.038	
IP.38	119523.000	44434.039	
IP.39	119524.000	44434.040	
IP.40	119525.000	44434.041	
IP.41	119526.000	44434.042	
IP.42	119527.000	44434.043	
IP.43	119528.000	44434.044	
IP.44	119529.000	44434.045	
IP.45	119530.000	44434.046	
IP.46	119531.000	44434.047	
IP.47	119532.000	44434.048	
IP.48	119533.000	44434.049	
IP.49	119534.000	44434.050	
IP.50	119535.000	44434.051	
IP.51	119536.000	44434.052	
IP.52	119537.000	44434.053	
IP.53	119538.000	44434.054	
IP.54	119539.000	44434.055	
IP.55	119540.000	44434.056	
IP.56	119541.000	44434.057	
IP.57	119542.000	44434.058	
IP.58	119543.000	44434.059	
IP.59	119544.000	44434.060	
IP.60	119545.000	44434.061	
IP.61	119546.000	44434.062	
IP.62	119547.000	44434.063	
IP.63	119548.000	44434.064	
IP.64	119549.000	44434.065	
IP.65	119550.000	44434.066	
IP.66	119551.000	44434.067	
IP.67	119552.000	44434.068	
IP.68	119553.000	44434.069	
IP.69	119554.000	44434.070	
IP.70	119555.000	44434.071	
IP.71	119556.000	44434.072	
IP.72	119557.000	44434.073	
IP.73	119558.000	44434.074	
IP.74	119559.000	44434.075	
IP.75	119560.000	44434.076	
IP.76	119561.000	44434.077	
IP.77	119562.000	44434.078	
IP.78	119563.000	44434.079	
IP.79	119564.000	44434.080	
IP.80	119565.000	44434.081	
IP.81	119566.000	44434.082	
IP.82	119567.000	44434.083	
IP.83	119568.000	44434.084	
IP.84	119569.000	44434.085	
IP.85	119570.000	44434.086	
IP.86	119571.000	44434.087	
IP.87	119572.000	44434.088	
IP.88	119573.000	44434.089	
IP.89	119574.000	44434.090	
IP.90	119575.000	44434.091	
IP.91	119576.000	44434.092	
IP.92	119577.000	44434.093	
IP.93	119578.000	44434.094	
IP.94	119579.000	44434.095	
IP.95	119580.000	44434.096	
IP.96	119581.000	44434.097	
IP.97	119582.000	44434.098	
IP.98	119583.000	44434.099	
IP.99	119584.000	44434.100	
IP.100	119585.000	44434.101	
IP.101	119586.000	44434.102	
IP.102	119587.000	44434.103	
IP.103	119588.000	44434.104	
IP.104	119589.000	44434.105	
IP.105	119590.000	44434.106	
IP.106	119591.000	44434.107	
IP.107	119592.000	44434.108	
IP.108	119593.000	44434.109	
IP.109	119594.000	44434.110	
IP.110	119595.000	44434.111	
IP.111	119596.000	44434.112	
IP.112	119597.000	44434.113	
IP.113	119598.000	44434.114	
IP.114	119599.000	44434.115	
IP.115	119600.000	44434.116	
IP.116	119601.000	44434.117	
IP.117	119602.000	44434.118	
IP.118	119603.000	44434.119	
IP.119	119604.000	44434.120	
IP.120	119605.000	44434.121	
IP.121	119606.000	44434.122	
IP.122	119607.000	44434.123	
IP.123	119608.000	44434.124	
IP.124	119609.000	44434.125	
IP.125	119610.000	44434.126	
IP.126	119611.000	44434.127	
IP.127	119612.000	44434.128	
IP.128	119613.000	44434.129	
IP.129	119614.000	44434.130	
IP.130	119615.000	44434.131	
IP.131	119616.000	44434.132	
IP.132	119617.000	44434.133	
IP.133	119618.000	44434.134	
IP.134	119619.000	44434.135	
IP.135	119620.000	44434.136	
IP.136	119621.000	44434.137	
IP.137	119622.000	44434.138	
IP.138	119623.000	44434.139	
IP.139	119624.000	44434.140	
IP.140	119625.000	44434.141	
IP.141	119626.000	44434.142	
IP.142	119627.000	44434.143	
IP.143	119628.000	44434.144	
IP.144	119629.000	44434.145	
IP.145	119630.000	44434.146	
IP.146	119631.000	44434.147	
IP.147	119632.000	44434.148	
IP.148	119633.000	44434.149	
IP.149	119634.000	44434.150	
IP.150	119635.000	44434.151	
IP.151	119636.000	44434.152	
IP.152	119637.000	44434.153	
IP.153	119638.000	44434.154	
IP.154	119639.000	44434.155	
IP.155	119640.000	44434.156	
IP.156	119641.000	44434.157	
IP.157	119642.000	44434.158	
IP.158	119643.000	44434.159	
IP.159	119644.000	44434.160	
IP.160	119645.000	44434.161	
IP.161	119646.000	44434.162	
IP.162	119647.000	44434.163	
IP.163	119648.000	44434.164	
IP.164	119649.000	44434.165	
IP.165	119650.000	44434.166	
IP.166	119651.000	44434.167	
IP.167	119652.000	44434.168	
IP.168	119653.000	44434.169	
IP.169	119654.000	44434.170	
IP.170	119655.000	44434.171	
IP.171	119656.000	44434.172	
IP.172	119657.000	44434.173	
IP.173	119658.000	44434.174	
IP.174	119659.000	44434.175	
IP.175	119660.000	44434.176	
IP.176	119661.000	44434.177	
IP.177	119662.000	44434.178	
IP.178	119663.000	44434.179	
IP.179	119664.000	44434.180	
IP.180	119665.000	44434.181	
IP.181	119666.000	44434.182	
IP.182	119667.000	44434.183	
IP.183	119668.000	44434.184	
IP.184	119669.000	44434.185	
IP.185	119670.000	44434.186	
IP.186	119671.000	44434.187	
IP.187	119672.000	44434.188	
IP.188	119673.000	44434.189	
IP.189	119674.000	44434.190	
IP.190	119675.000	44434.191	
IP.191	119676.000	44434.192	
IP.192	119677.000	44434.193	
IP.193	119678.000	44434.194	
IP.194	119679.000	44434.195	
IP.195	119680.000	44434.196	
IP.196	119681.000	44434.197	
IP.197	119682.000	44434.198	
IP.198	119683.000	44434.199	
IP.199	119684.000	44434.200	
IP.200	119685.000	44434.201	
IP.201	119686.000	44434.202	
IP.202	119687.000	44434.203	
IP.203	119688.000	44434.204	
IP.204	119689.000	44434.205	
IP.205	119690.000	44434.206	
IP.206	119691.000	44434.207	
IP.207	119692.000	44434.208	
IP.208	119693.000	44434.209	
IP.209	119694.000	44434.210	
IP.210	119695.000	44434.211	
IP.211	119696.000	44434.212	
IP.212	119697.000	44434.213	
IP.213	119698.000	44434.214	
IP.214	119699.000	44434.215	
IP.215	119700.000	44434.216	
IP.216	119701.000	44434.217	
IP.217	119702.000	44434.218	
IP.218	119703.000	44434.219	
IP.219	119704.000	44434.220	
IP.220	119705.000	44434.221	
IP.221	119706.000	44434.222	
IP.222	119707.000	44434.223	
IP.223	119708.000	44434.224	
IP.224	119709.000	44434.225	
IP.225	119710.000	44434.226	
IP.226	119711.000	44434.227	
IP.227	119712.000	44434.228	
IP.228	119713.000	44434.229	
IP.229	119714.000	44434.230	
IP.230	119715.000	44434.231	
IP.231	119716.000	44434.232	
IP.232	119717.000	44434.233	
IP.233	119718.000	44434.234	
IP.234	119719.000	44434.235	
IP.235	119720.000	44434.236	
IP.236	119721.000	44434.237	
IP.237	119722.000	44434.238	
IP.238	119723.000	44434.239	
IP.239	119724.000	44434.240	
IP.240	119725.000	44434.241	
IP.241	119726.000	44434.242	
IP.242	119727.000	44434.243	
IP.243	119728.000	44434.244	
IP.244	119729.000	44434.245	
IP.245	119730.000	44434.246	
IP.246	119731.000	44434.247	
IP.247	119732.000	44434.248	
IP.248	119733.000	44434.249	
IP.249	119734.000	44434.250	
IP.250	119735.000	44434.251	
IP.251	119736.000	44434.252	
IP.252	119737.000	44434.253	
IP.253	119738.000	44434.254	
IP.254	119739.000	44434.255	
IP.255	119740.000	44434.256	
IP.256	119741.000	44434.257	
IP.257	119742.000	44434.258	
IP.258	119743.000		

0+8.522 (I P. 1)

GH=35.870
FH=35.870

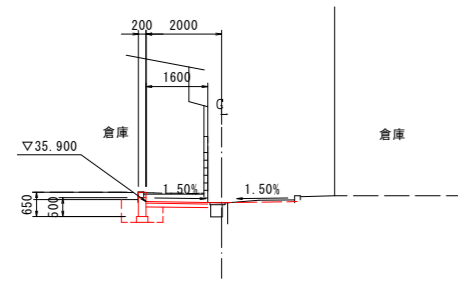

	左	右
掘削	0.3	---
床堀	0.6	---
埋戻(内)	0.2	---
埋戻(外)	0.2	---
CO取壊し	0.3	---
AS掘削	---	---
舗装工	1.60	

DL=32.000

+3.75

GH=36.191
FH=36.170

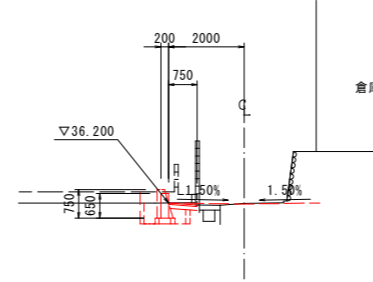

	左	右
掘削	0.5	---
床堀	0.7	---
埋戻(内)	0.2	---
埋戻(外)	0.4	---
CO取壊し	0.17	---
AS掘削	---	---
舗装工	0.75	

DL=33.000

No. 2

GH=36.495
FH=36.490

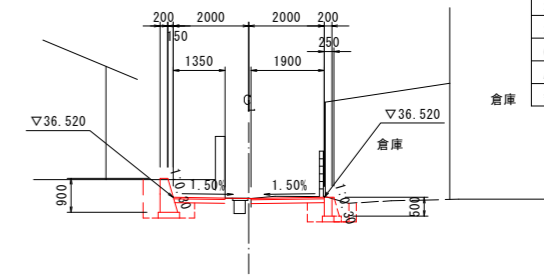

	左	右
掘削	1.0	0.2
床堀	0.8	0.7
埋戻(内)	0.3	0.3
埋戻(外)	0.5	0.2
CO取壊し	0.34	0.13
AS掘削	---	1.8
舗装工	3.25	

DL=33.000

+3.00

GH=35.770
FH=35.857

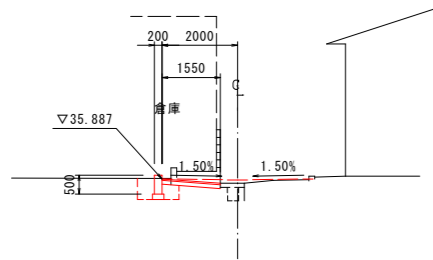

	左	右
掘削	0.1	---
床堀	0.7	---
埋戻(内)	0.2	---
埋戻(外)	0.2	---
CO取壊し	0.34	---
AS掘削	---	---
舗装工	1.55	

DL=32.000

No. 1

GH=36.106
FH=36.096

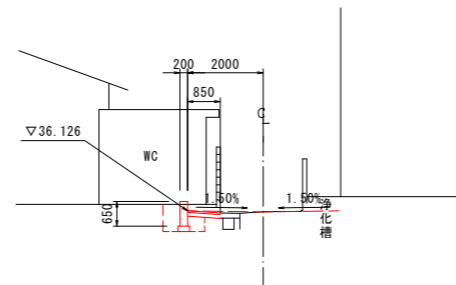

	左	右
掘削	0.5	---
床堀	0.6	---
埋戻(内)	0.2	---
埋戻(外)	0.3	---
CO取壊し	0.21	---
AS掘削	---	---
舗装工	0.85	

DL=32.000

+11.50

GH=36.319
FH=36.323

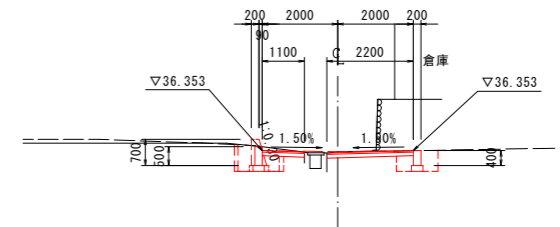

	左	右
掘削	0.2	0.2
床堀	0.8	0.6
埋戻(内)	0.2	0.2
埋戻(外)	0.3	0.2
CO取壊し	---	---
AS掘削	---	1.2
舗装工	3.30	

DL=33.000

No. 0

GH=35.852
FH=35.850

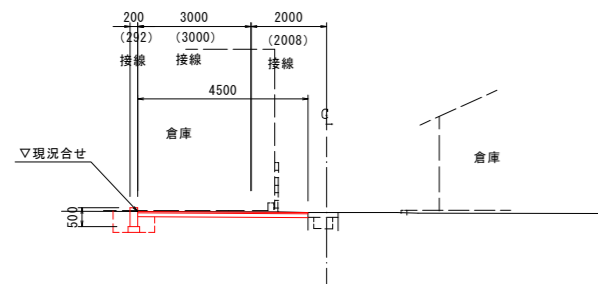

	左	右
掘削	0.4	---
床堀	0.6	---
埋戻(内)	0.2	---
埋戻(外)	0.2	---
CO取壊し	0.56	---
AS掘削	0.7	---
舗装工	4.50	

DL=32.000

0+15.774 (I P. 2)

GH=36.053
FH=36.013

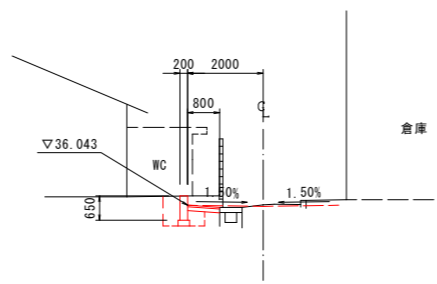

	左	右
掘削	0.4	---
床堀	0.6	---
埋戻(内)	0.2	---
埋戻(外)	0.3	---
CO取壊し	0.18	---
AS掘削	---	---
舗装工	0.80	

DL=32.000

図面番号	第 3 号	図面総数	6 葉
図名	横断面 1/2 縮尺 図示		
名称	市道東整理馬場線改良工事		
施行箇所	阿波市阿波町馬場		
工事種別	道路改良工事		
所属年度	令和 8 年度	工事番号	
市長	設計	製図	阿波市建設課

No. 3

GH=36.987
FH=37.053

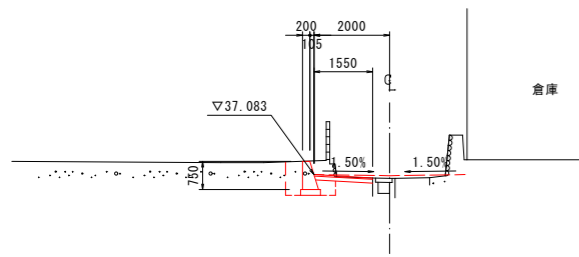

DL=33.000

	左	右
掘削	0.6	---
床堀	0.7	---
埋戻(内)	0.2	---
埋戻(外)	0.3	---
CO取壊し	0.17	---
AS掘削	0.9	---
舗装工	1.55	

No. 4

GH=37.555
FH=37.555

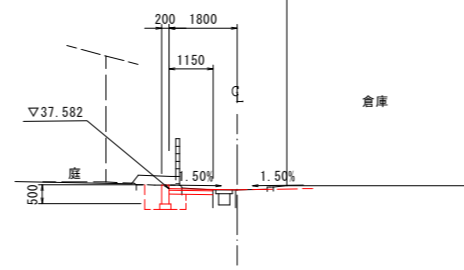

DL=33.000

	左	右
掘削	0.4	---
床堀	0.6	---
埋戻(内)	0.2	---
埋戻(外)	0.3	---
CO取壊し	0.13	---
AS掘削	0.8	---
舗装工	1.35	

NO. 4+12.68 (EP)

GH=37.881
FH=37.880

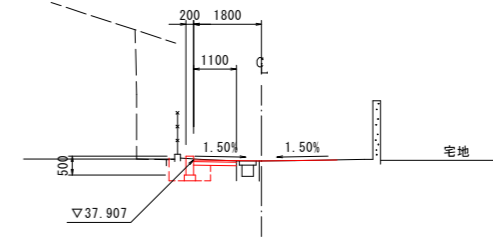

DL=35.000

	左	右
掘削	0.2	---
床堀	0.6	---
埋戻(内)	0.2	---
埋戻(外)	0.2	---
CO取壊し	0.03	---
AS掘削	1.4	---
舗装工	1.30	

NO. 2+13.70

GH=36.884
FH=36.896

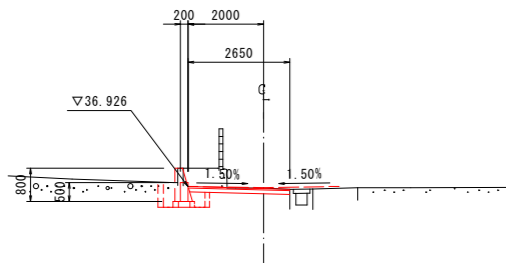

DL=33.000

	左	右
掘削	0.7	---
床堀	0.7	---
埋戻(内)	0.2	---
埋戻(外)	0.2	---
CO取壊し	0.20	---
AS掘削	1.6	---
舗装工	2.65	

NO. 3+12.00

GH=37.349
FH=37.350

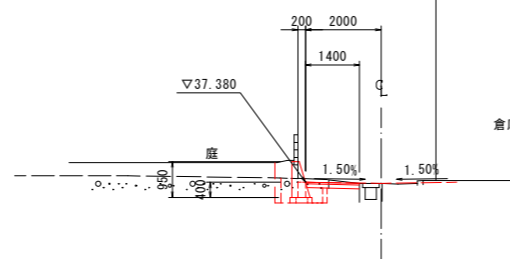

DL=33.000

	左	右
掘削	0.4	---
床堀	0.8	---
埋戻(内)	0.2	---
埋戻(外)	0.4	---
CO取壊し	0.10	---
AS掘削	0.8	---
舗装工	1.40	

NO. 4+7.00

GH=37.739
FH=37.734

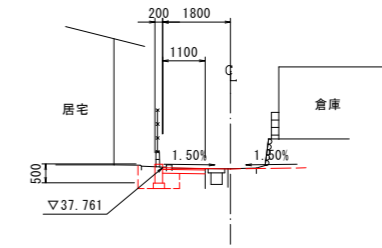

DL=33.000

	左	右
掘削	0.2	---
床堀	0.6	---
埋戻(内)	0.2	---
埋戻(外)	0.2	---
CO取壊し	0.05	---
AS掘削	0.8	---
舗装工	1.30	

NO. 2+8.200

GH=36.764
FH=36.760

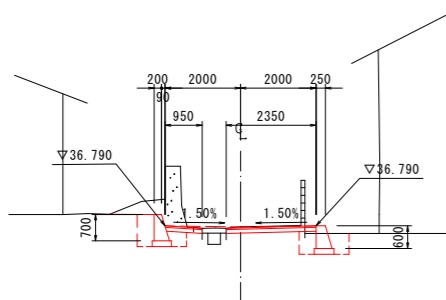

DL=33.000

	左	右
掘削	0.6	0.2
床堀	0.7	0.7
埋戻(内)	0.3	0.3
埋戻(外)	0.4	0.3
CO取壊し	0.51	0.15
AS掘削	0.2	1.9
舗装工	3.30	

NO. 3+4.00

GH=37.088
FH=37.152

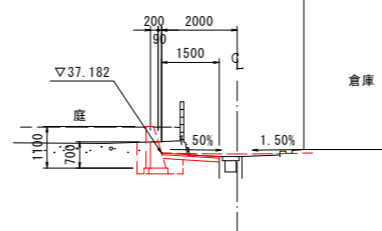

DL=33.000

	左	右
掘削	0.5	---
床堀	0.6	---
埋戻(内)	0.2	---
埋戻(外)	0.3	---
CO取壊し	0.11	---
AS掘削	0.8	---
舗装工	1.50	

図面番号	第 4 号	図面総数	6 葉
図名	横断面 2/2 縮尺 図示		
名称	市道東整理馬場線改良工事		
施行箇所	阿波市阿波町馬場		
工事種別	道路改良工事		
所属年度	令和 8 年度	工事番号	
市長	設計	製図	阿波市建設課

展開図
SH=1/200
SV=1/50

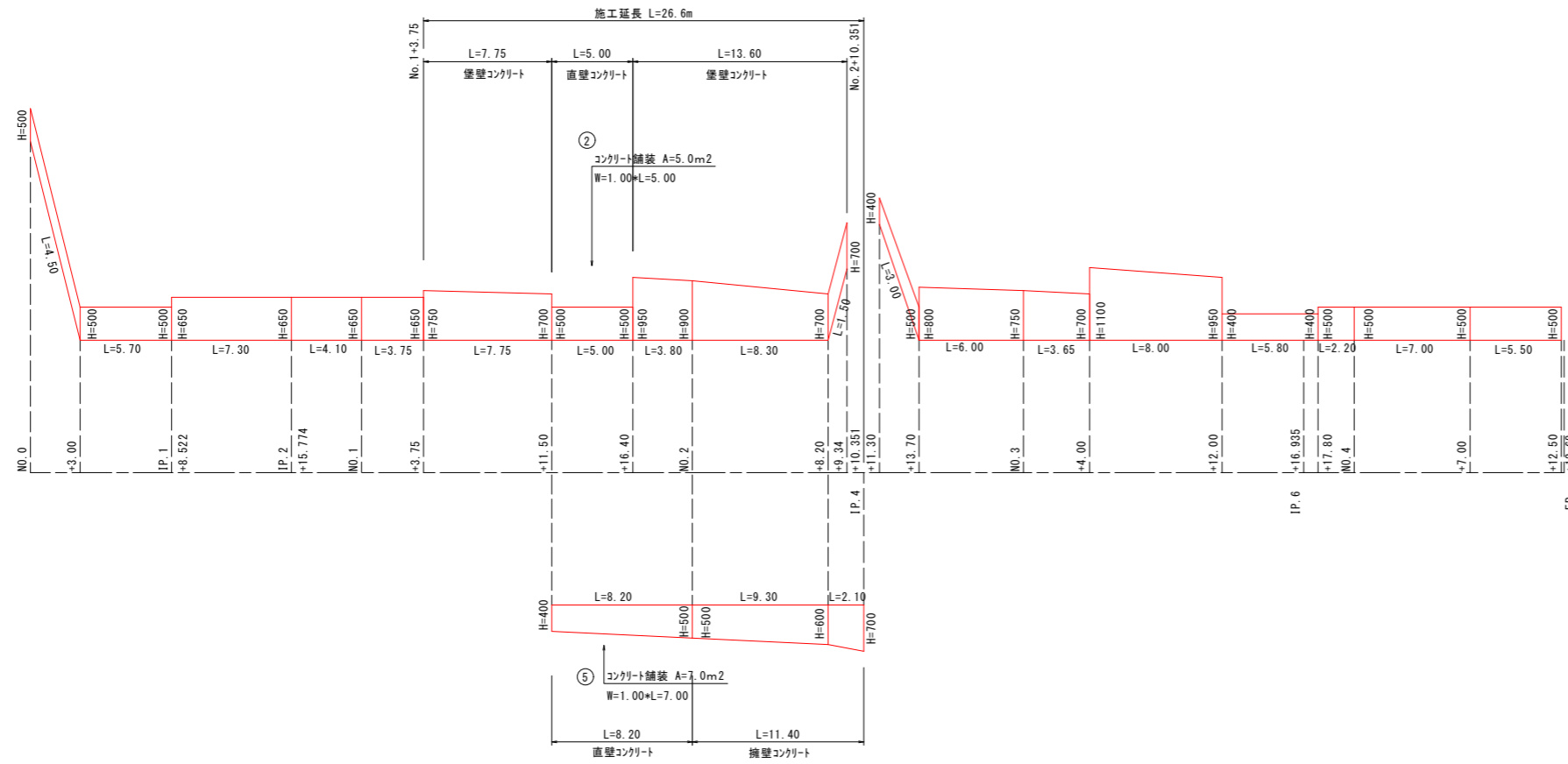

構造図

擁壁コンクリート
S=1/20

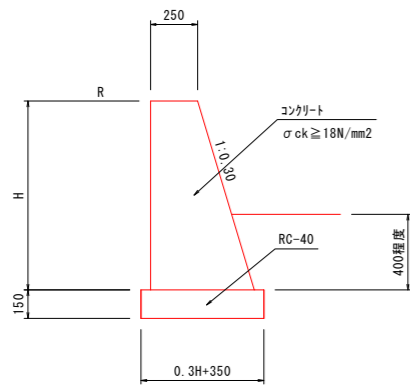

堡壁コンクリート
S=1/20

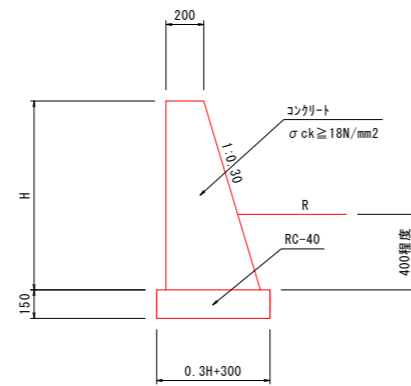

直壁コンクリート
S=1/20

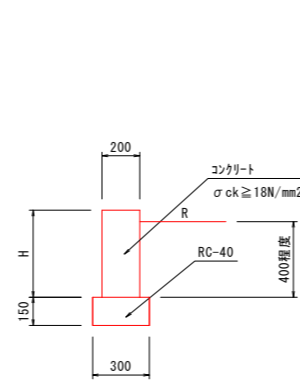

舗装構成

アスファルト舗装

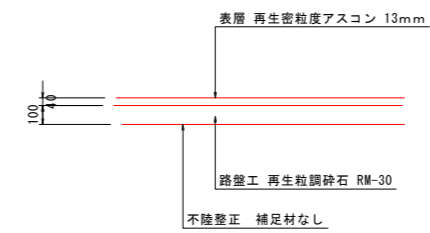

コンクリート舗装

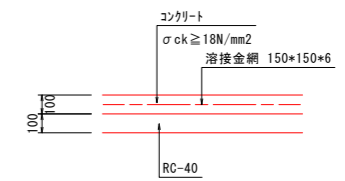

図面番号	第 5 号	図面総数	6 葉
図名	展開図・構造図		縮尺 図示
名称	市道東整理馬場線改良工事		
施行箇所	阿波市阿波町馬場		
工事種別	道路改良工事		
所属年度	令和 8 年度	工事番号	
市長	設計	製図	阿波市建設課